

25mm Mixer Cartridges

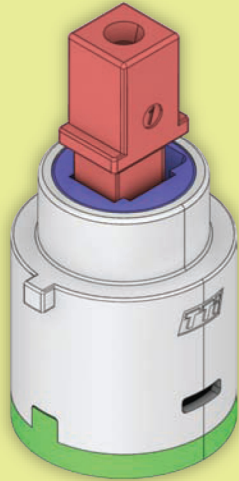

**MC25B-1
MC25B-2**

**MC25BH-1
MC25BH-2**

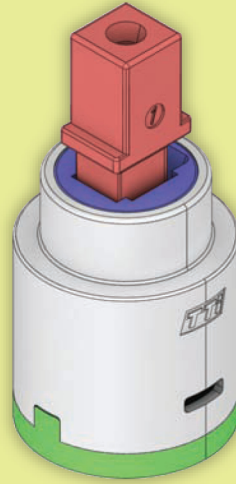
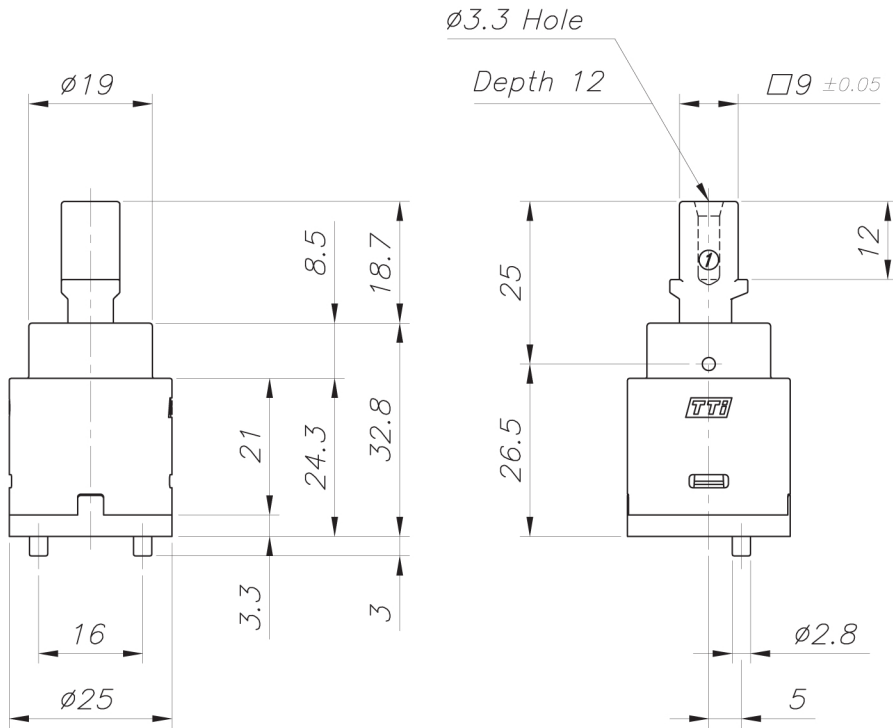

MC25B-1

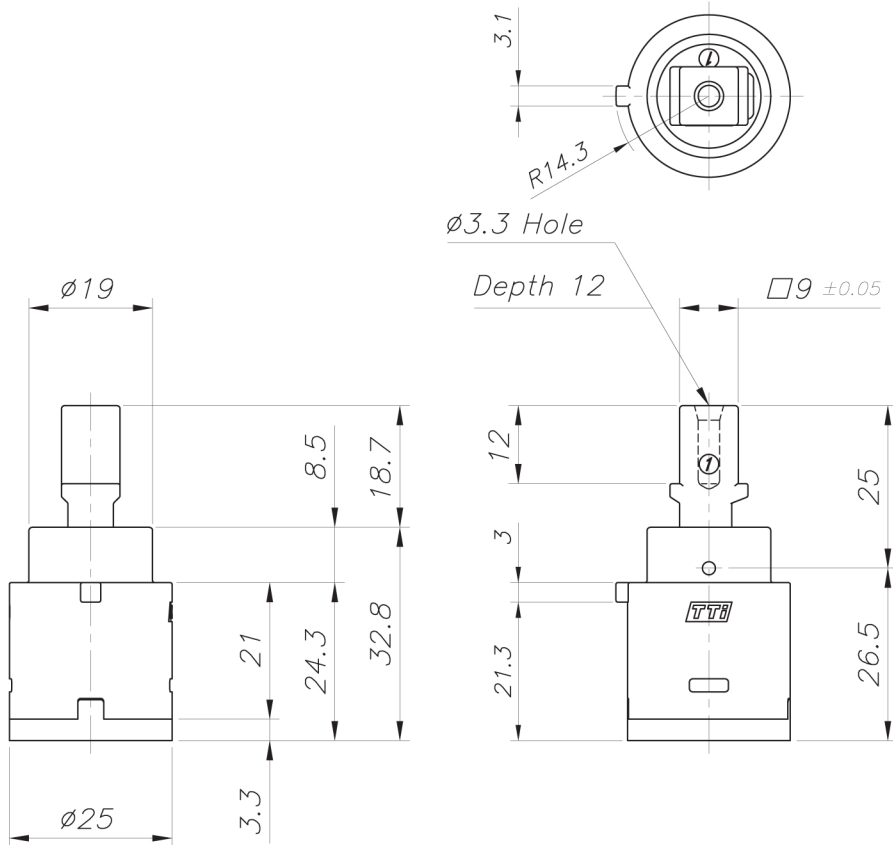

MC25BH-1

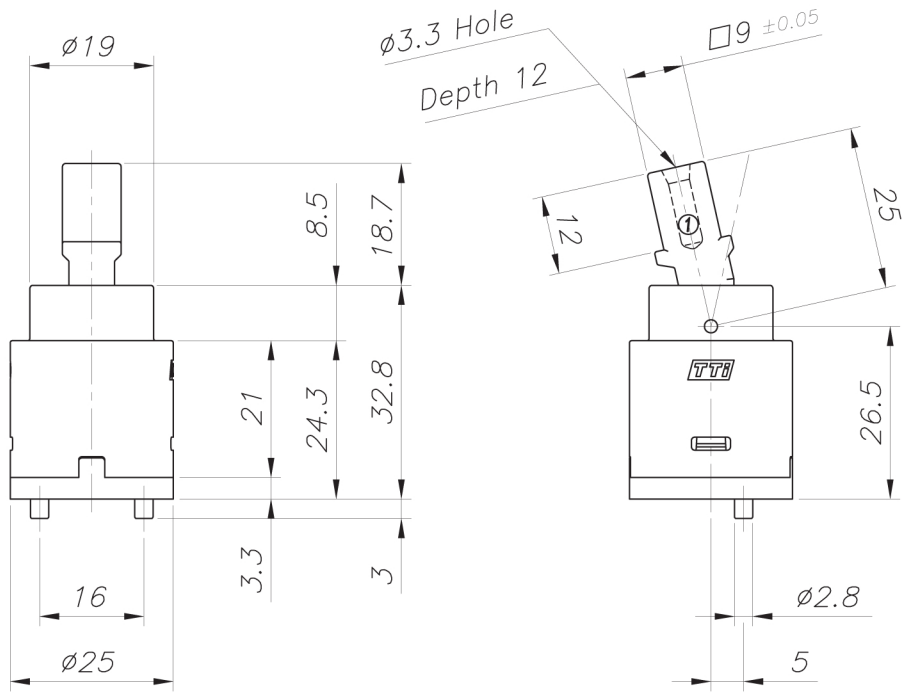

MC25B-2

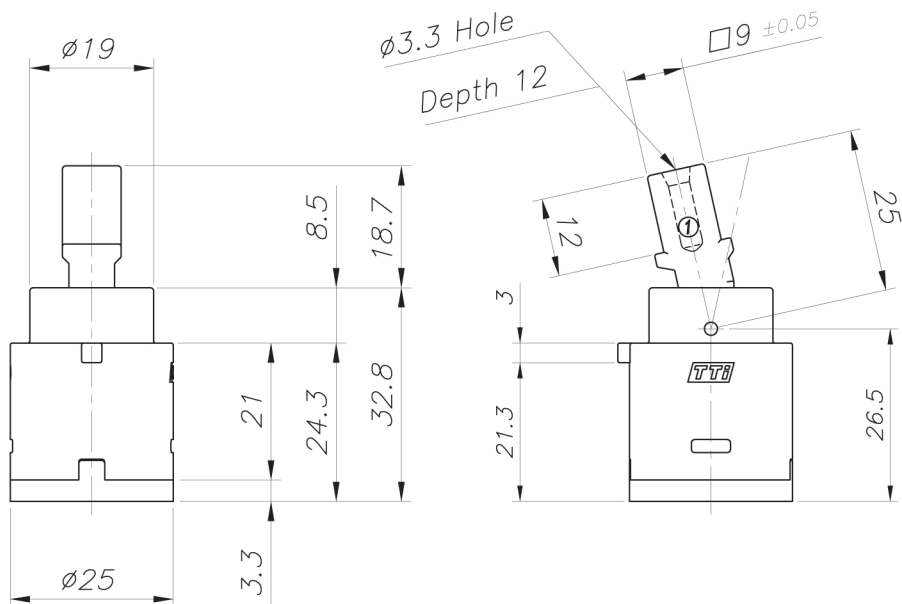
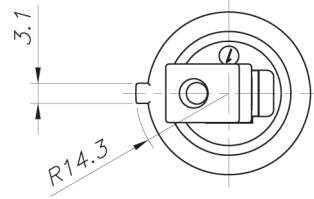

MC25BH-2

Cartridge Data

Opening angle	25°
Mixing angle	90°
Working torque	Max. 0.5Kg-Cm
Pressure resistance	min. 25bars
Working pressure	max. 7bars
Max. temperature	90°C
Max. noise	19db (A) at 3bars
Endurance test	min. 500,000 cycles
Cartridge tightening torque	100 ~ 110Kg-Cm

Flow Rate Curves

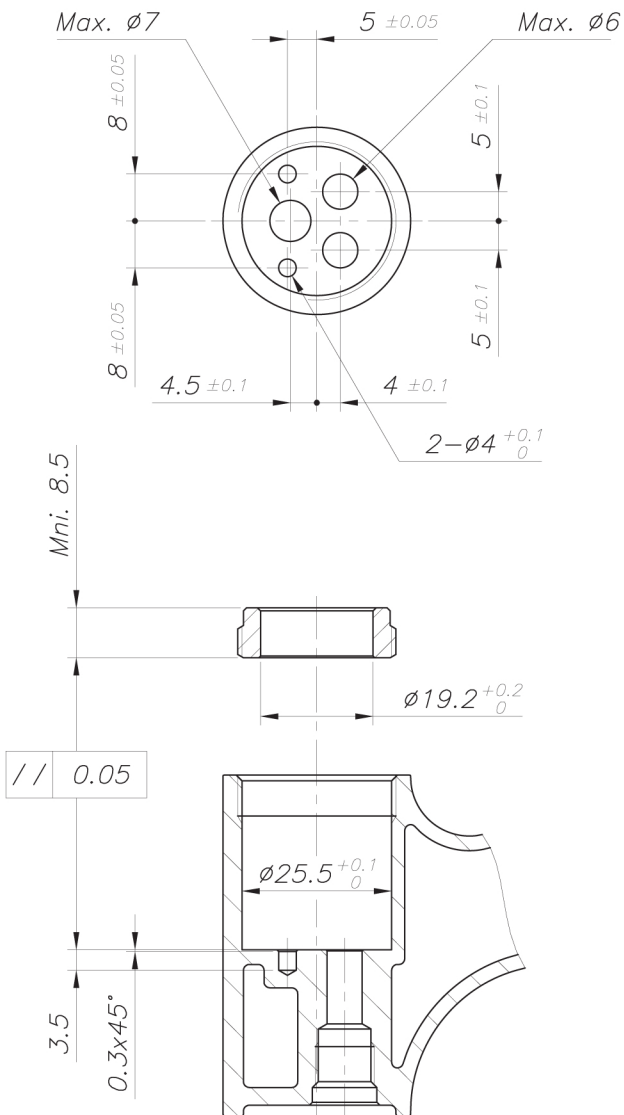
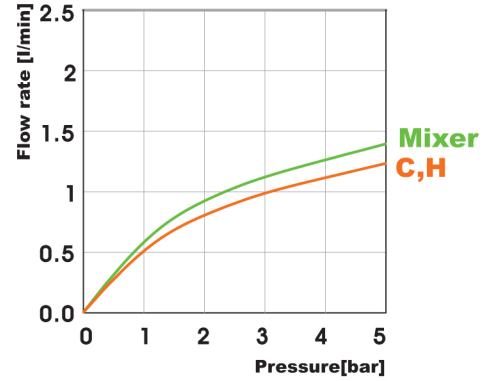

MC25B-1,2

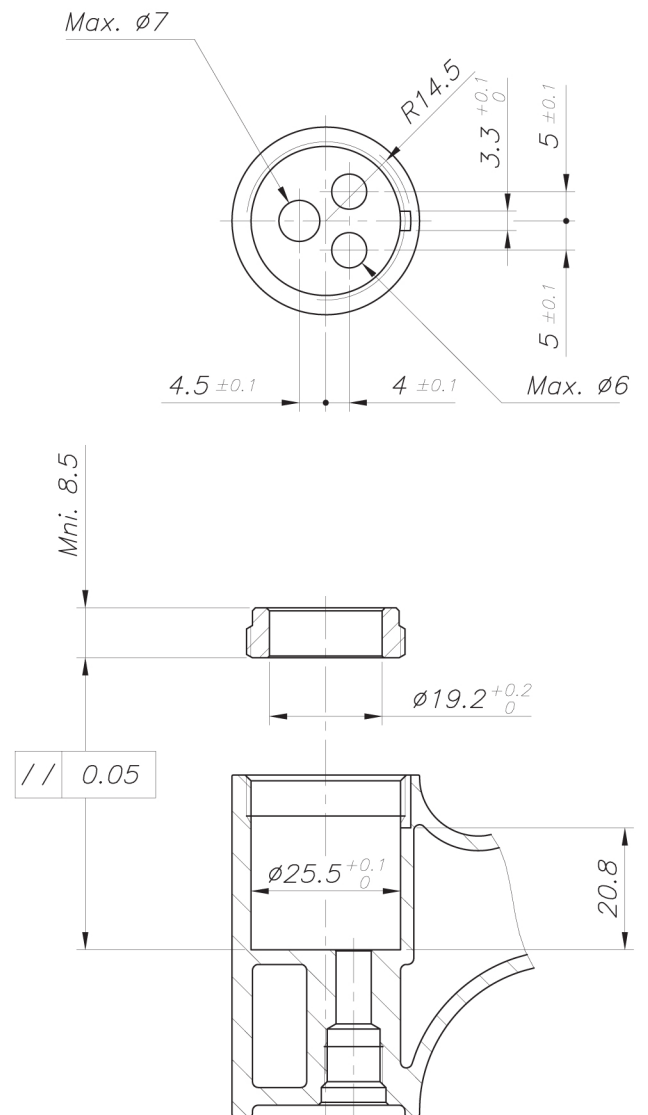

MC25BH-1,2