

30mm Mixer Cartridges

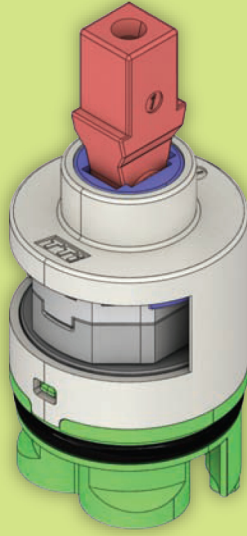

MC30A

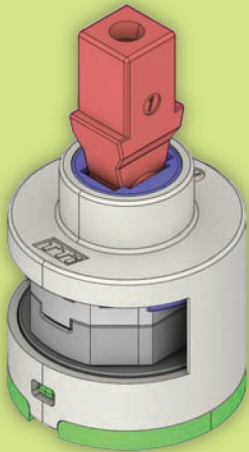

MC30B

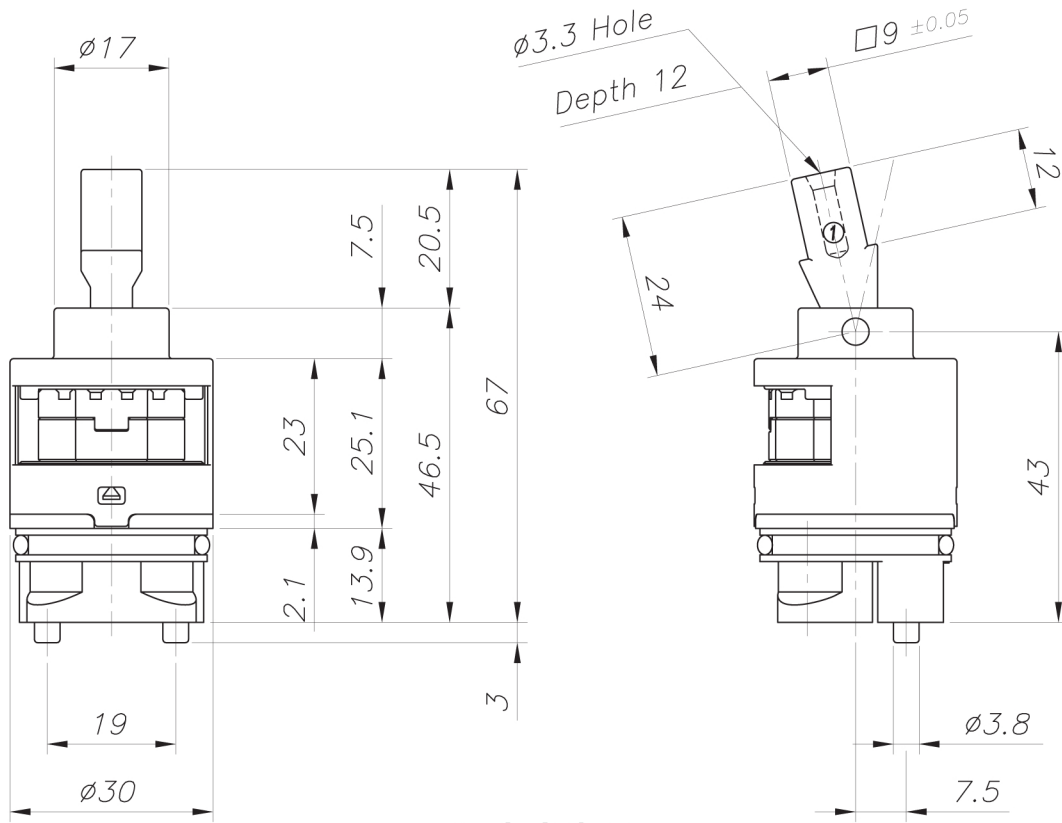

MC30A

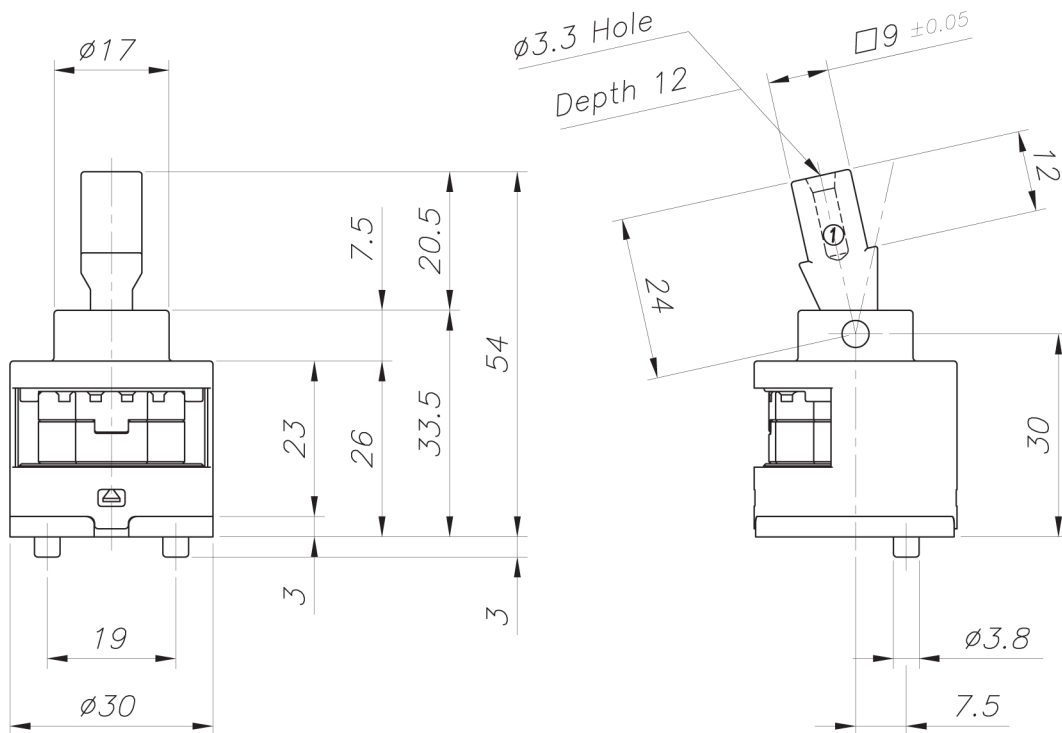

MC30B

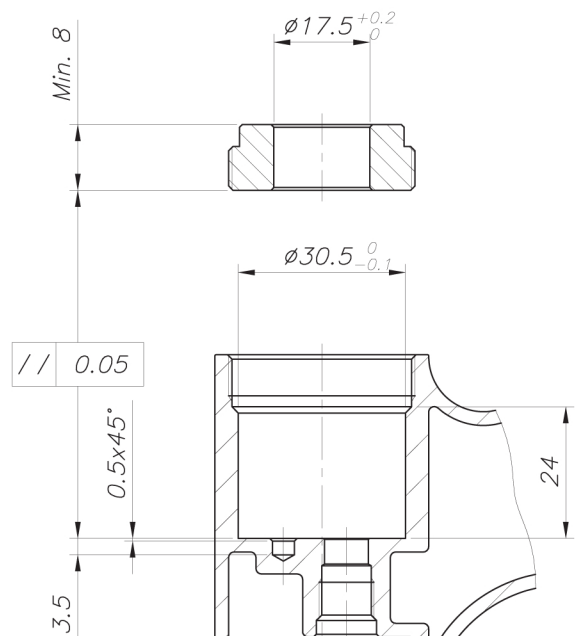
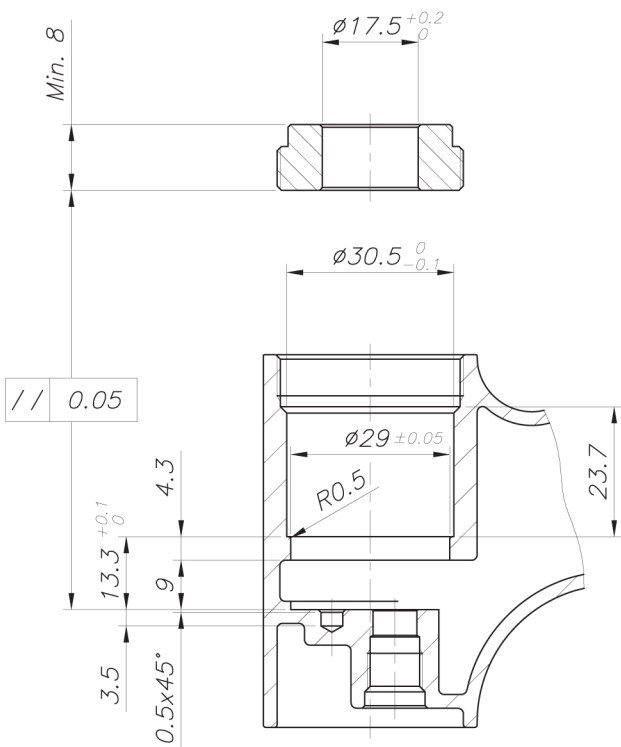
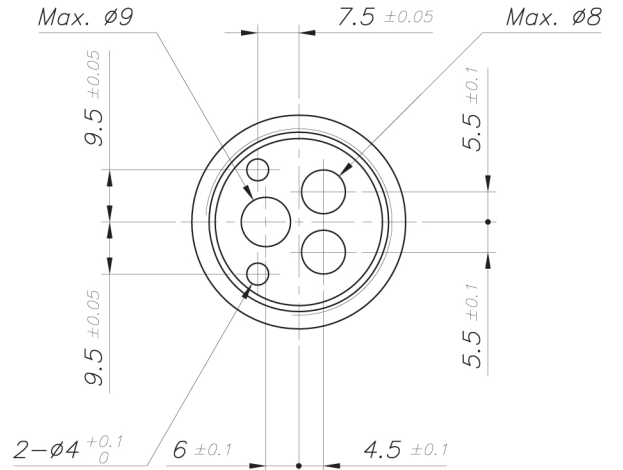
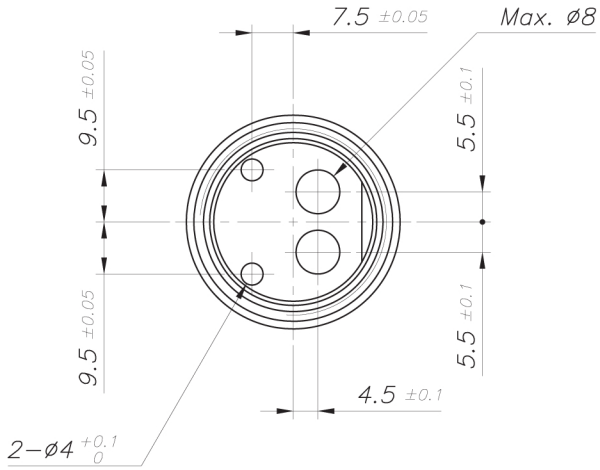

MC30A

MC30B

Cartridge Data

Opening angle	25°
Mixing angle	90°
Working torque	Max. 0.5Kg-Cm
Pressure resistance	min. 25bars
Working pressure	max. 7bars
Max. temperature	90°C
Max. noise	19db (A) at 3bars
Endurance test	min. 500,000 cycles
Cartridge tightening torque	100 ~ 110Kg-Cm

Flow Rate Curves

