

35mm TPS Cartridges

TPS35AD-1

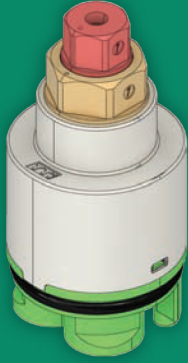

TPS35BD-1

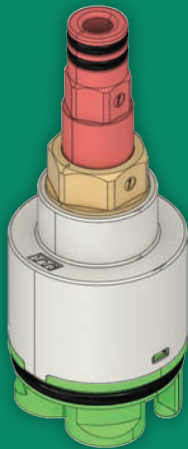
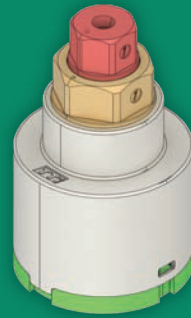

**TPS35AU
TPS35AD-2**

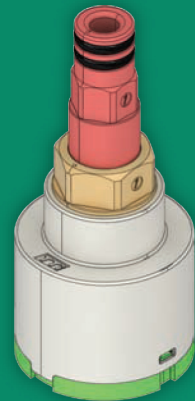

**TPS35BU
TPS35BD-2**

Cartridge Data

On-Off angle	90°
Temperature angle	90°
On-Off Working torque	Max. 0.2Kg-Cm
Temperature Working torque	Max. 0.7Kg-Cm
Pressure resistance	min. 25bars
Working pressure	max. 7bars
Max. temperature	90°C
Max. noise	19db (A) at 3bars
Endurance test	min. 500,000 cycles
Cartridge tightening torque	100 ~ 110Kg-Cm

Flow Rate Curves

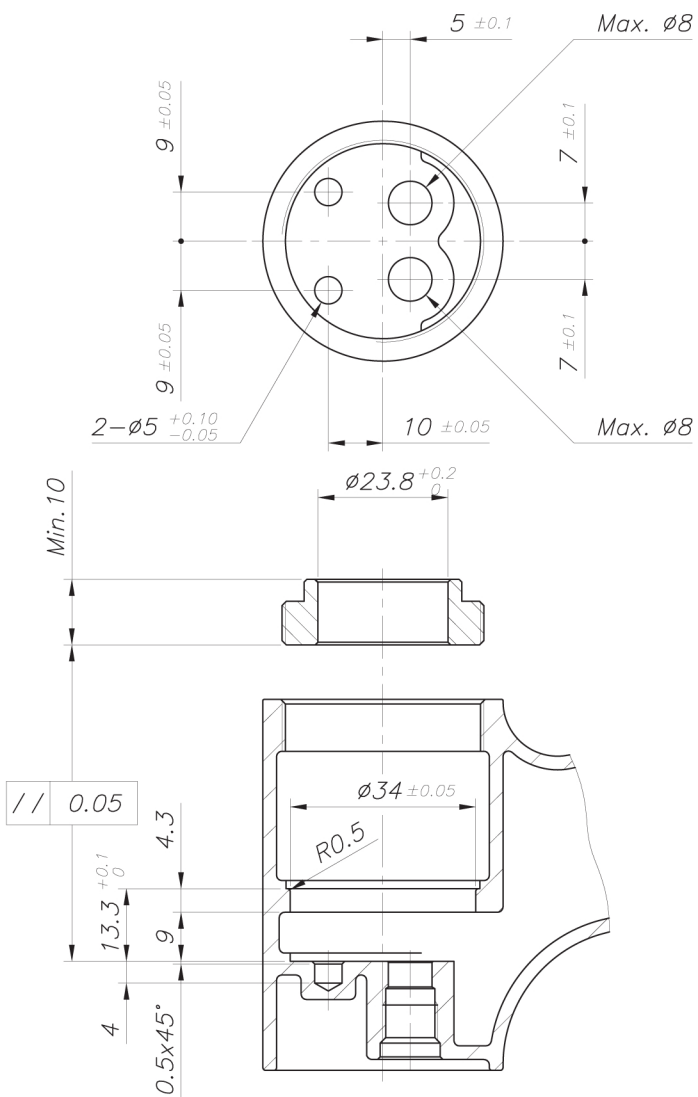
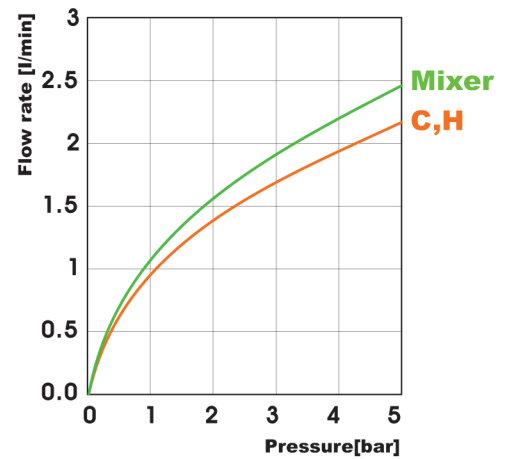

TPS35AU

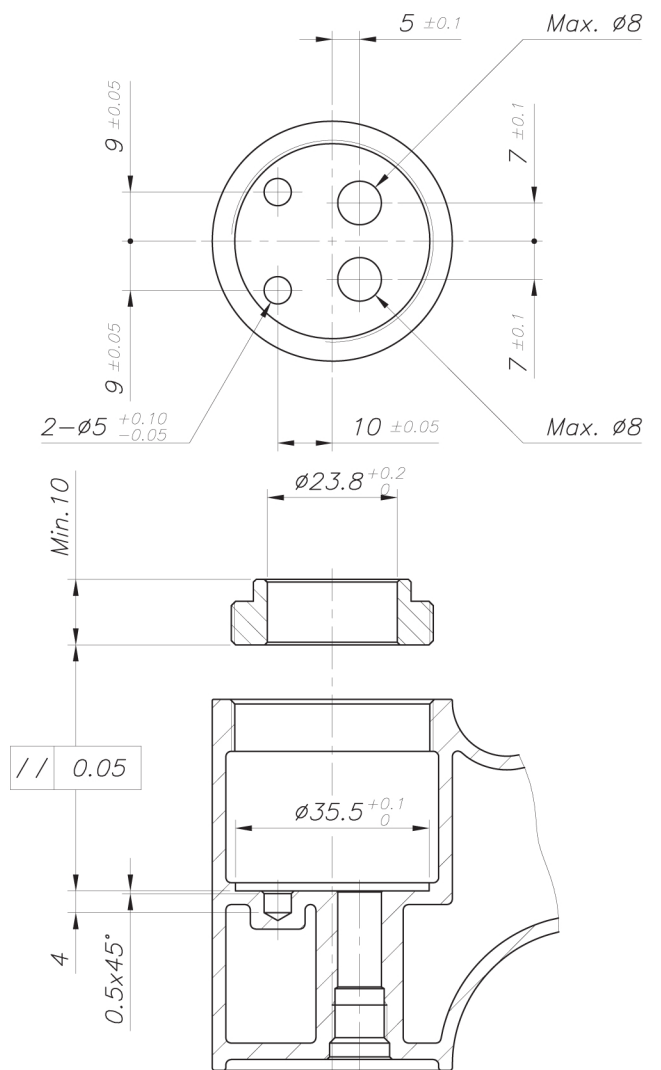

TPS35BU

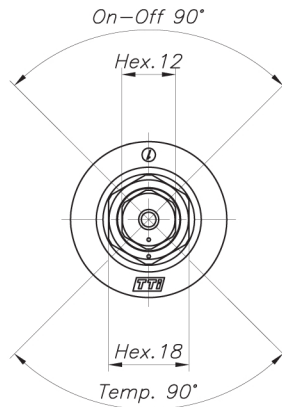

Note
To be used with check valves

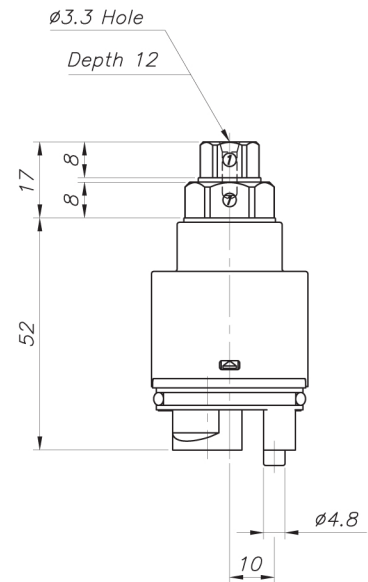
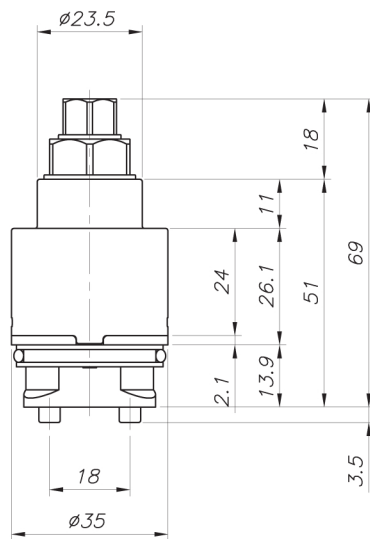
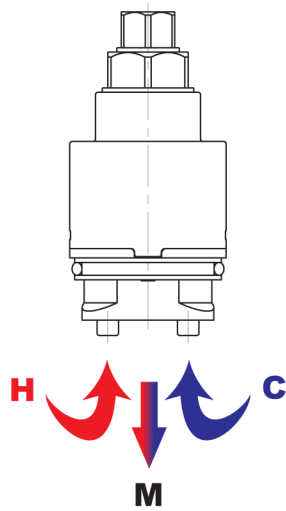

TPS35AD-1

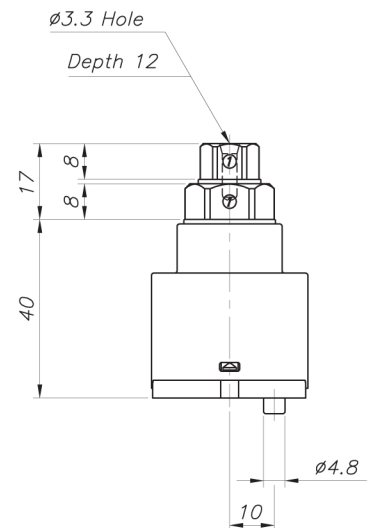
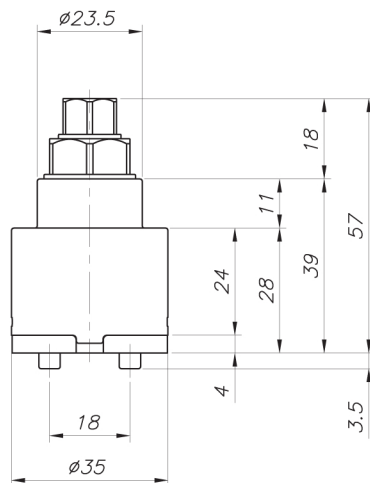
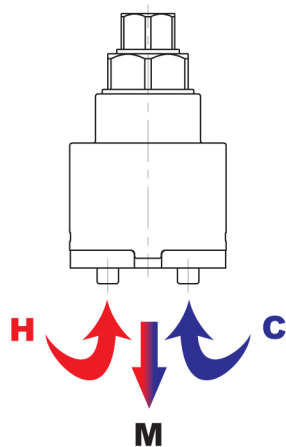

TPS35BD-1



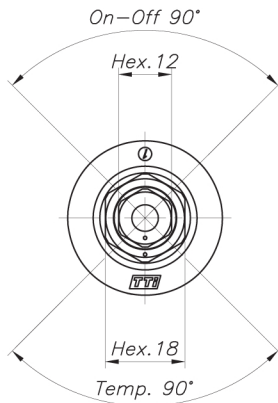

Note
To be used with check valves

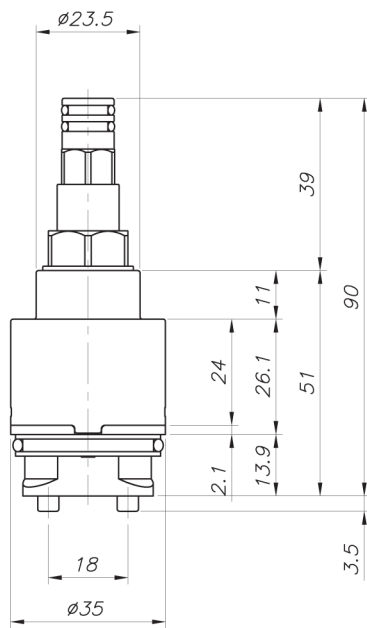
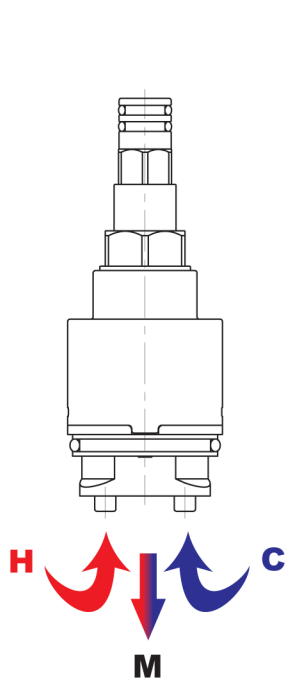

TPS35AD-2

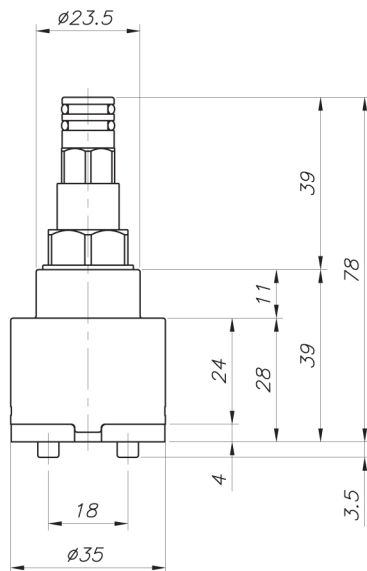
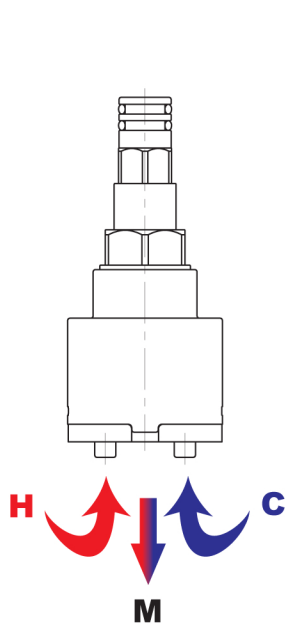
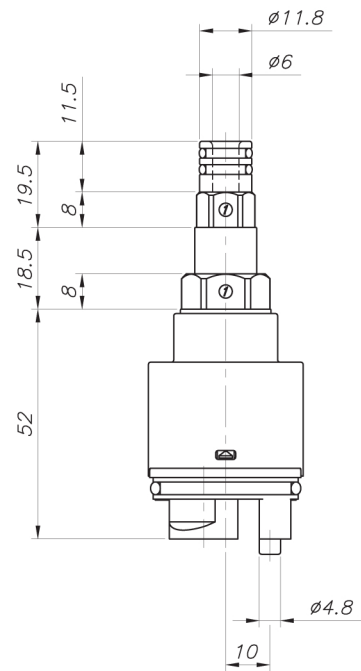

TPS35BD-2

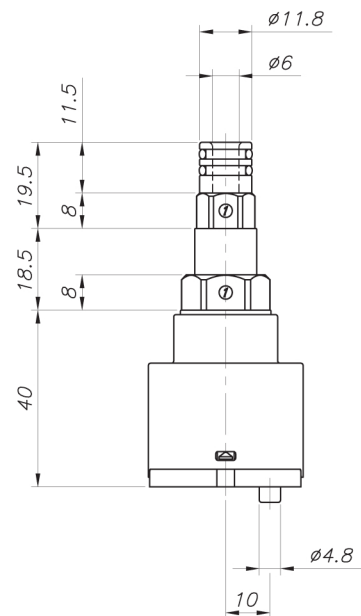



Cartridge Data

On-Off angle	90°
Temperature angle	90°
On-Off Working torque	Max. 0.2Kg-Cm
Temperature Working torque	Max. 0.7Kg-Cm
Pressure resistance	min. 25bars
Working pressure	max. 7bars
Max. temperature	90°C
Max. noise	19db (A) at 3bars
Endurance test	min. 500,000 cycles
Cartridge tightening torque	100 ~ 110Kg-Cm

Flow Rate Curves

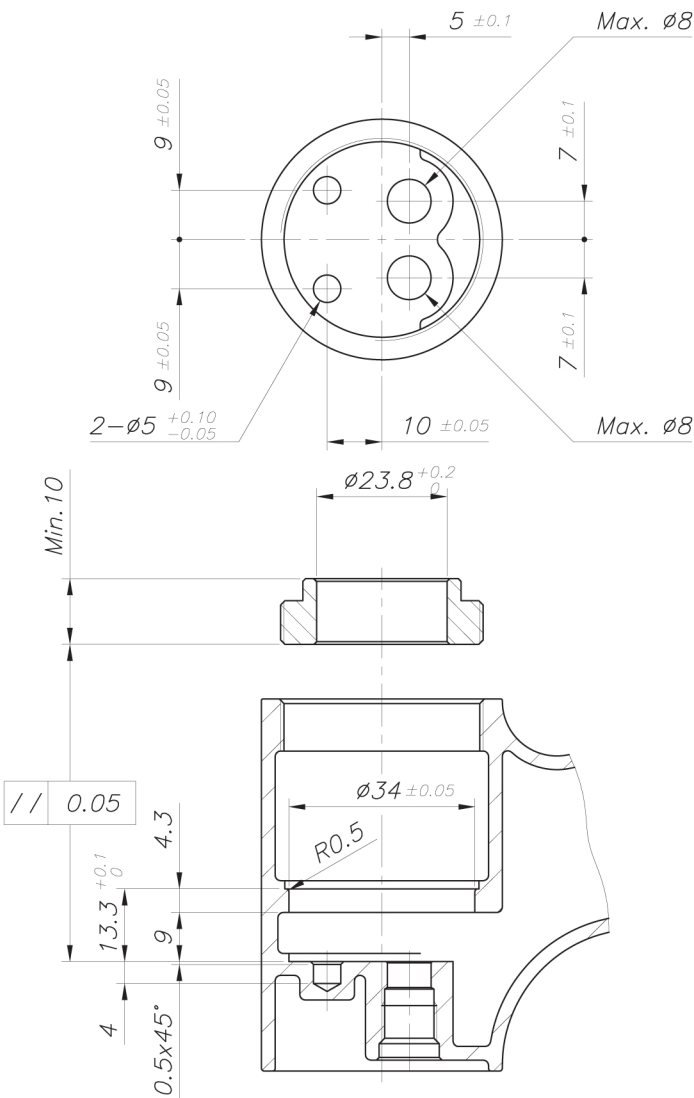
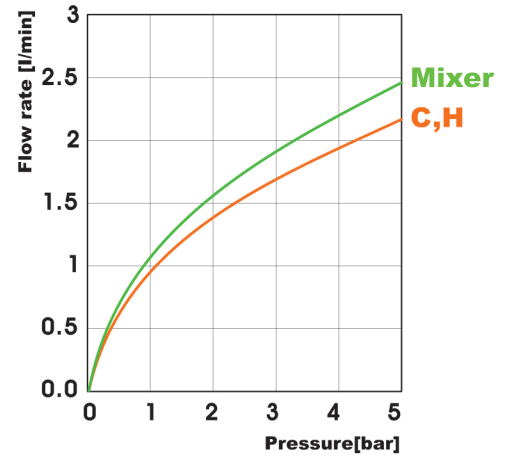



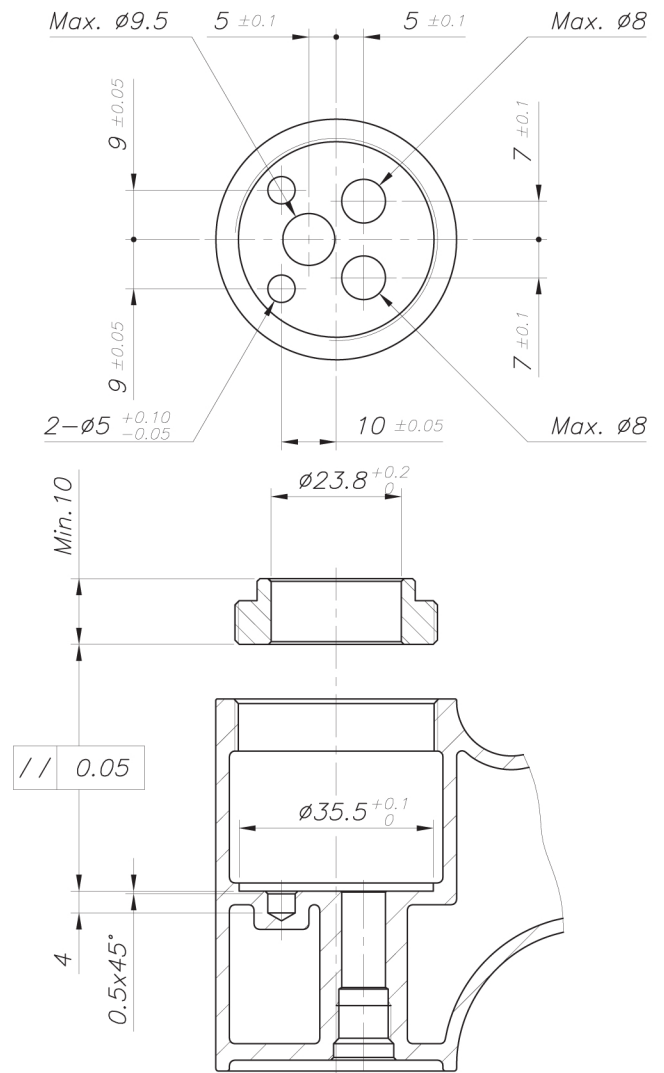

TPS35AD-1,2

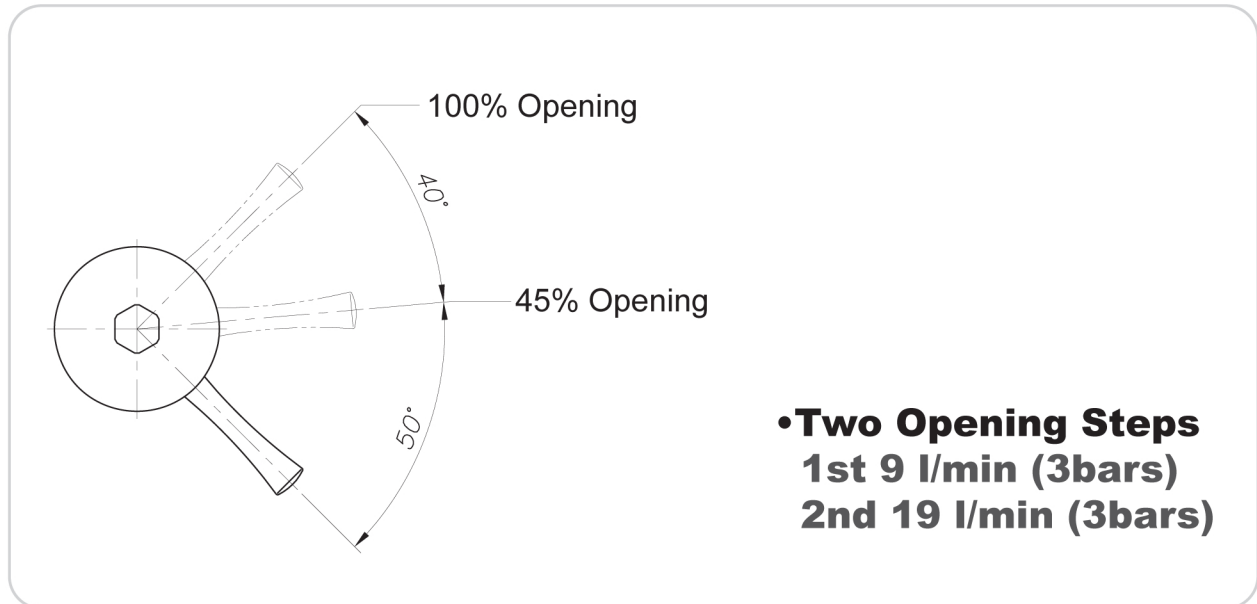

TPS35BD-1,2

Two Steps for Water Saving

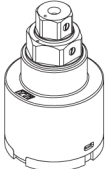
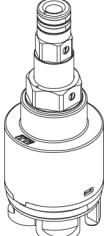
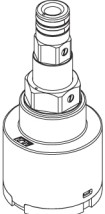

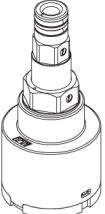
	Down Flow				Upper Flow	
						
Standard	TPS35AD-1	TPS35BD-1	TPS35AD-2	TPS35BD-2	TPS35AU	TPS35BU
Two Steps	TPS35ADS-1	TPS35BDS-1	TPS35ADS-2	TPS35BDS-2	TPS35AUS	TPS35BUS

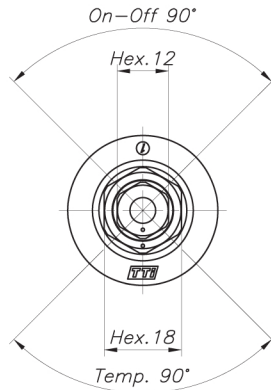

Note

TO BE USED WITH CHECK VALVE

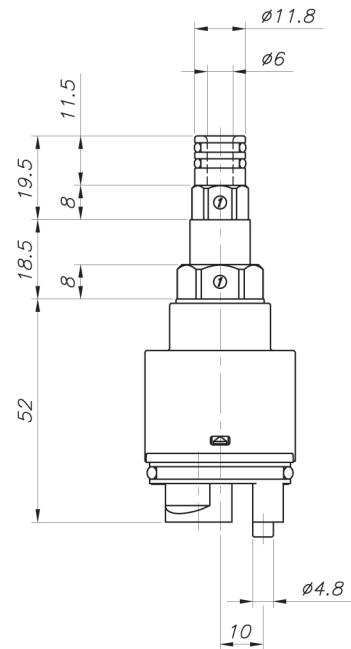
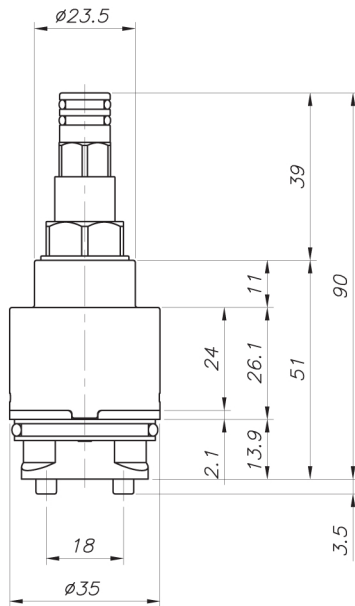
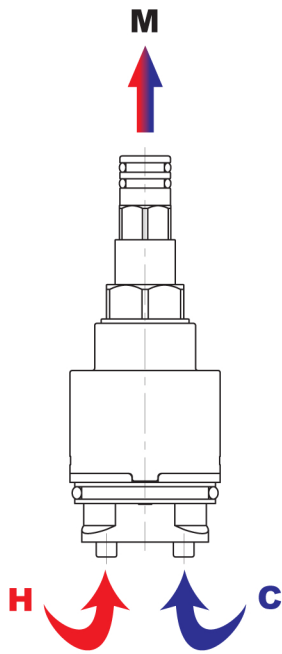

TPS35AU

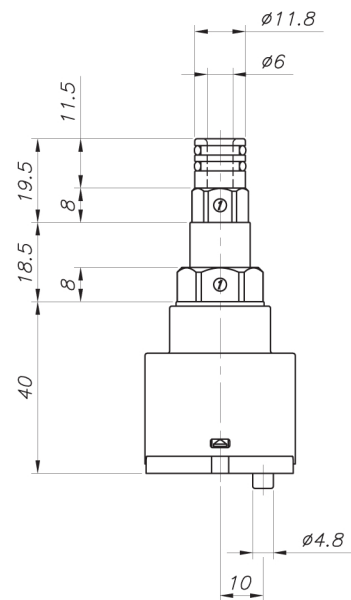
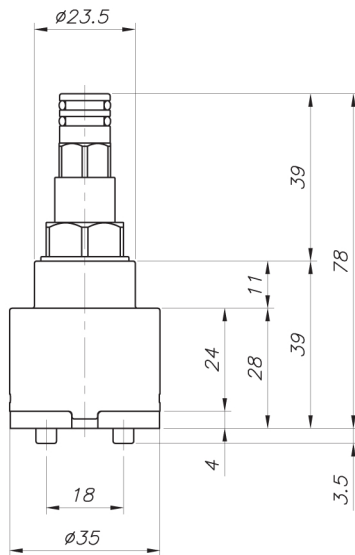
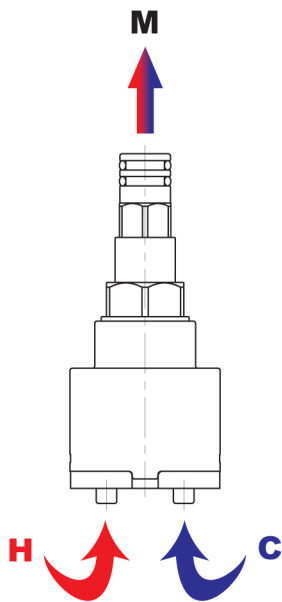

TPS35BU

